

## INSTRUCTION MANUAL



### SCENE SET-UP

#### 1 Install the Wallscape FX Activator™ on your Wall

Before installing your Activator, move the function switch on the back of the Activator from "Try Me" to "Play". This will enable full special effects functionality.

The Activator should only be mounted on a vertical surface. For optimal results, place a nail or screw into the wall approximately 4 feet from the floor. Then, position the Activator onto the wall by placing the hang hole on the back of activator directly over the nail until securely in place.

Note: For rooms with ceilings higher than 8 feet, you may want to position the activator higher than 4 feet to ensure that the light sufficiently illuminates the wall and the ceiling.

#### 2 Wall Decal Preparation **DO NOT SKIP THIS STEP**

After removing the decals from the package, roll out the sheet and lay flat for 24 – 48 hours until the sheet no longer wants to curl back up.

For best results apply the decals onto smooth, clean surfaces. The decals may not stick to heavily textured surfaces. Do not apply to fresh paint or wallpaper. Let the new paint/wallpaper dry for at least 3 weeks. Before applying the decals to wallpaper or other delicate surfaces, test one in an inconspicuous area. Keep the decals away from cribs and out of reach of young children to prevent choking hazard.

#### 3 Create your Scene by placing the Wall Decals

To apply each decal, carefully peel it off from the sheet. Then, place and smooth the decal onto your wall in the desired location. To remove or reposition each decal, just carefully peel it off from the wall. Kids can follow the suggested scene layout or customize and create their own scene. For optimal function with the light effects, please note the following suggestions on wall decal placement:

- Begin with Ariel's tail positioned 6 inches above the top of the Activator.
- Place all other decals around the Ariel decal but ideally no more than 36 inches above the top of the Activator. This will help to ensure that all decals are illuminated by the light cast.

4 On textured walls, periodically check the decals to make sure they are remaining flat against the surface. Gently smooth any parts of the decal, that appear to be lifting off the surface. Repeat as needed until the decals remain flat against the surface.

#### Wallscape FX Activator™

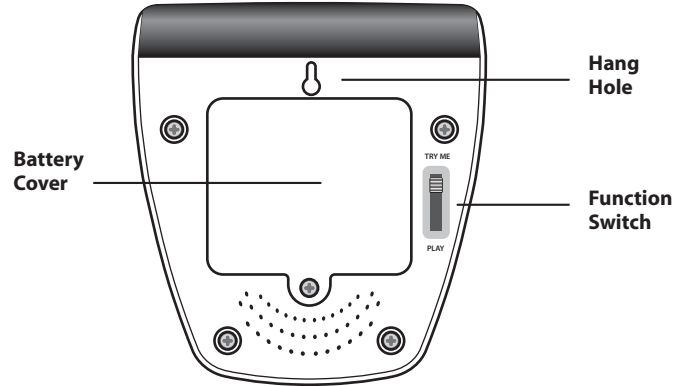

#### Scene Set-Up

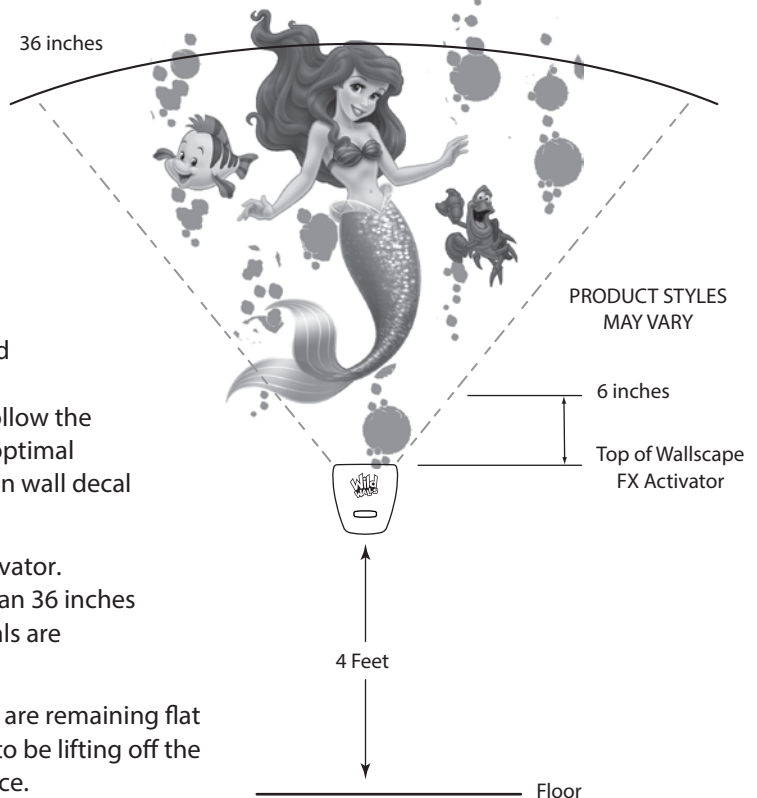

**WARNING:**  
CHOKING HAZARD - Small parts.  
Not for children under 3 years.  
Adult assembly required.

## SCENE ACTIVATION

Now you can activate your scene using different programming modes on the Activator as follows:

### TRY ME (10 second demo)

This is the factory default program and is used for in store demonstration. It is not intended for home use and has limited functionality. For full functionality, move the function switch on the back of the Activator from "Try Me" to "Play".

### MODE 1 – FULL FUNCTIONALITY LIGHT & SOUND SHOW

Press the program button once to activate. This will enable full light and sound special effects including the following:

- Music and undersea sound effects
- Light gently fading in and out, illuminating your wall and ceiling
- Synchronized lights and sounds that bring the scene to life.

In this mode, auto shut-off of the sound will occur approximately after 5 minutes and auto shut-off of the light will occur approximately after 10 minutes.

### MODE 2 – LIGHT SHOW ONLY

Press the program button two times to activate. This will enable full light functionality but will not include any sound effects. Auto shut-off will occur approximately after 20 minutes.

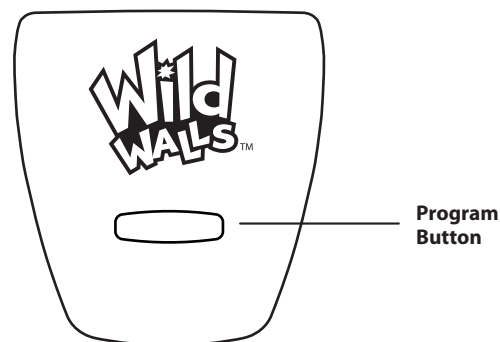

## MANUAL SHUT-OFF

To manually turn off the Activator, press and hold down the program button for approximately two seconds until the light and sound turns off.

## BATTERY REPLACEMENT

Tool required - Small Phillips head screwdriver  
Requires 3 AA/LR6 alkaline batteries.

1. Using a Phillips head screwdriver, remove the battery cover.
2. Insert 3 AA/LR6 alkaline batteries as indicated in the battery compartment and replace cover.
3. **IMPORTANT!** Switch the Activator to the PLAY position before hanging on the wall.

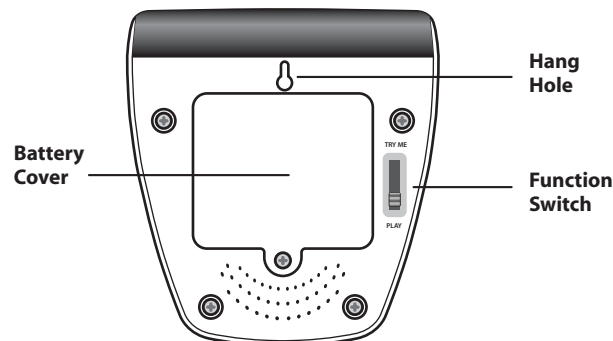

NOTE: This equipment has been tested and found to comply with the limits for a Class B digital device, pursuant to Part 15 of the FCC Rules. These limits are designed to provide reasonable protection against harmful interference in a residential installation. This equipment generates, uses and can radiate radio frequency energy and, if not installed and used in accordance with the instructions, may cause harmful interference to radio communications. However, there is no guarantee that interference will not occur in a particular installation. If this equipment does cause harmful interference to radio or television reception, which can be determined by turning the equipment off and on, the user is encouraged to try to correct the interference by one or more of the following measures:

- Reorient or relocate the receiving antenna.
- Increase the separation between the equipment and receiver.
- Connect the equipment into an outlet on a circuit different from that to which the receiver is connected.
- Consult the dealer or an experienced radio/TV technician for help.

**KEEP THESE INSTRUCTIONS FOR FUTURE REFERENCE — DO NOT DISCARD**

Questions? Visit [unclemilton.com](http://unclemilton.com)



MANUFACTURED BY UNCLE MILTON INDUSTRIES, INC.  
P.O. Box 6281, THOUSAND OAKS, CA 91359 USA  
©2013 UMI. All rights reserved. ® and TM designate trademarks of Uncle Milton Industries, Inc.  
MADE IN CHINA

This device complies with Part 15 of the FCC Rules.

Operation is subject to the following two conditions:

- (1) This device may not cause harmful interference, and
- (2) This device must accept any interference received, including interference that may cause undesired operation.

Caution: changes or modifications not expressly approved by the party responsible for compliance could void the user's authority to operate the equipment.

#### BATTERY SAFETY INFORMATION

- Non-rechargeable batteries are not to be recharged.
- Rechargeable batteries are to be removed from the toy before being charged.
- Rechargeable batteries are only to be charged under adult supervision.
- Different types of batteries or new and used batteries are not to be mixed.
- Batteries are to be inserted with the correct polarity.
- Exhausted batteries are to be removed from the toy.
- The supply terminals are not to be short-circuited.
- Do not mix old and new batteries.
- Do not mix alkaline, standard (carbon-zinc) or rechargeable (nickel-cadmium) batteries.
- Do not dispose of batteries in fire. Battery may explode or leak.